

COMFORT OF SILENCE

Second-to-none
noise absorbing performance

FiberAcoustic®



ACOUSTICS





Ceilings



Wall panels

FiberAcoustic®

– unique sound absorption

Unique sound absorption

Fibertex has designed a range of sound absorbing nonwoven products which offers manufacturers, architects and specifiers, advanced acoustic performance. Our high-performing acoustic materials provide the freedom to create optimal solutions by combining noise reduction, innovative design, enhanced aesthetics and optimum comfort.

We are here to inspire you and help you achieve superior acoustic performance in any project – whether it is for reducing noise in a home, hotel, office or car.

Allow us to work with you to design an efficient sound absorption system - from product specification to the final solution - according to your exact needs.

Noise is by definition annoying

Acoustic absorbers, diffusers and traps are usually used to actively dampen the noise within a room.

This is usually measured on the reverberation time within the room. Some examples hereof could be: A room with hard surfaces such as concrete walls, ceiling and floor can have a reverberation time up to more than a few seconds.

On the other end of the scale with music studios and concert halls you will usually have a reverberation time down to about 0.3 seconds.

There are different ways to decrease the reverberation time in a room, usually by acoustic adding acoustic dampeners, traps and diffusers.

These solutions can usually be in form of wall panels, ceiling tiles or acoustic carpets.

Our FiberAcoustic® products work as a trap for the sound waves and can be installed both in wall panels and ceilings, and often together with an acoustic absorber.

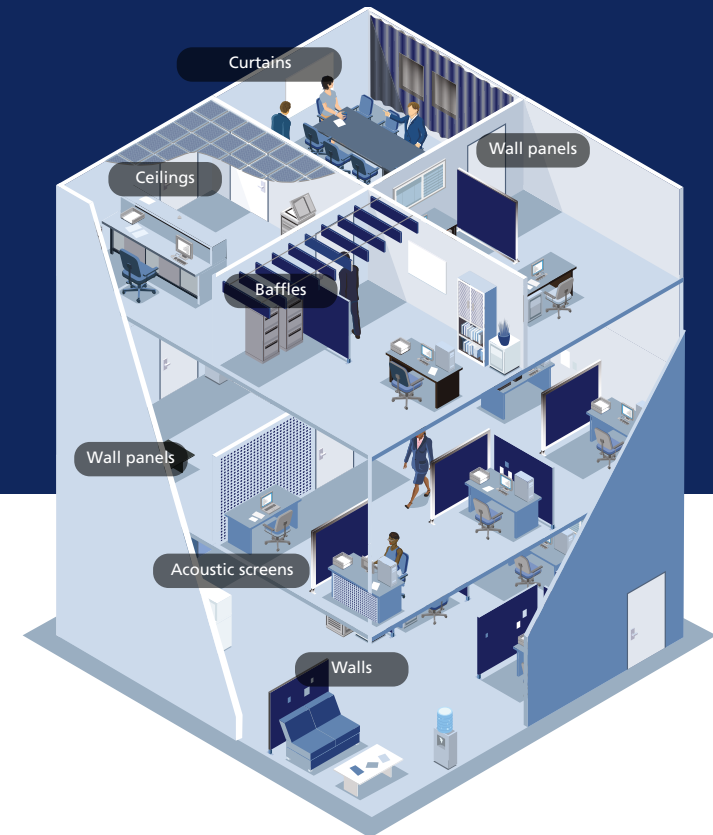

Applications

The FiberAcoustic® range consists of high-quality environmentally friendly soundproofing materials, with excellent acoustic properties and exceptional sound absorption, for suspended ceilings, wall panels, screens and floors.

These robust nonwoven materials are also suitable for use as efficient noise barriers in construction applications, as well as automotive and furniture design.

FiberAcoustic® – how it works

What is sound

Sound is changes in the air pressure, oscillating around the atmospheric pressure. For the human ear, the important parameters are the frequency and the sound level. The frequency is measured in Hertz (Hz) and describes how many times per second the sound pressure oscillates around the atmospheric pressure. At low frequencies the sound is low (bass) and at high frequencies the sound is high (treble). The sound level is measured in decibel (dB) on a logarithmic scale, and describes the deviation in air pressure from that of the ambient atmospheric pressure. Typical conversation is measured to be 60 dB, an increase to 70 dB will be perceived as a doubling of the sound intensity.

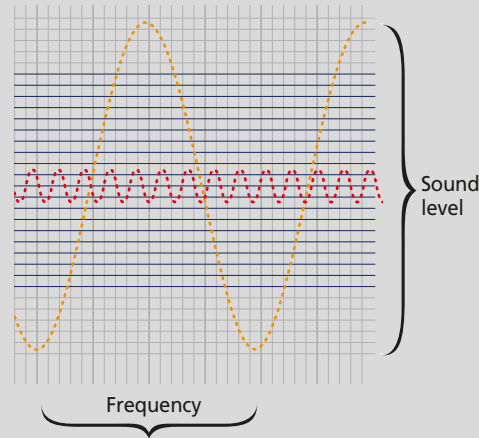

How it works

When a sound wave strikes the surface of a material, it is either reflected or it penetrates the material. If the acoustic impedance of this material is too high, the sound waves are reflected and if the acoustic impedance is too low, the sound waves penetrate the material without being absorbed. At the proper acoustic impedance of the material, the sound energy will be absorbed and converted into heat by viscous friction between the oscillating particles of the sound medium and the structure of the porous nonwoven material. FiberAcoustic® is specially developed for optimal acoustic performance in human spaces provided by tuned acoustic impedance within a broad spectrum of frequencies.

Sound absorption

Sound is pressure waves travelling through air. Sound absorption is the absorption of sound waves in a material and is the process where sound energy is dissipated into heat energy. The sound absorption properties of a material are characterised by the sound absorption coefficient α , and vary from 0 to 1. Sound absorption of a material is frequency dependent.

$\alpha = 1.0$ equals 100% sound absorption $\alpha = 0.0$ equals 0% sound absorption

Why air space behind FiberAcoustic®

The space behind FiberAcoustic® is essential for the acoustic performance since it controls the frequency at which maximum sound absorption is obtained. Wide space provides absorption at low frequencies; narrow space provides absorption at high frequencies. When a sound wave has entered the surface, the optimal acoustic impedance of FiberAcoustic® ensures that sound waves are encapsulated in the space behind FiberAcoustic®. Sound energy is removed by sound waves hitting back and forth between a solid surface and FiberAcoustic®.

The space behind FiberAcoustic® consists of either air or filling. With air as space, FiberAcoustic® ensures high acoustic performance, whereas filling moves the absorption slope towards lower frequencies.

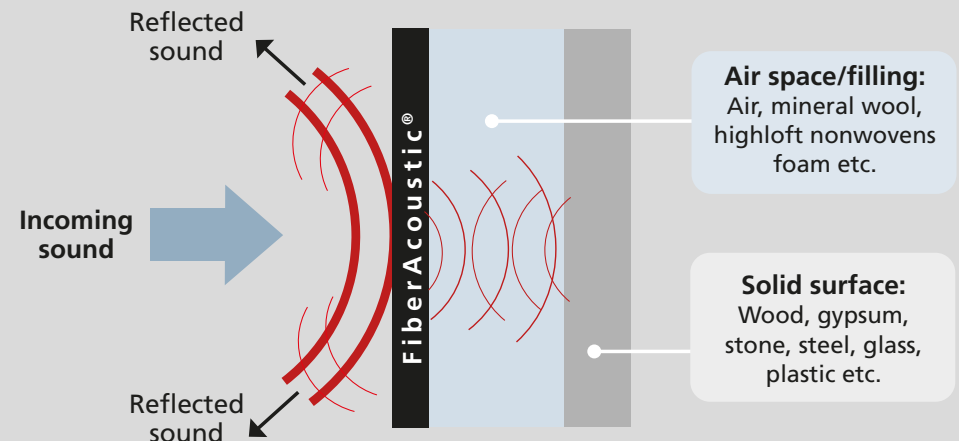

FiberAcoustic® – tested and well-documented

Sound measurements

At Fibertex Nonwovens, we have the capability and facilities to perform absorption tests according to EN ISO 10534-2. This method, known as the impedance tube measurement, is suitable for the initial testing of acoustic absorption properties and controls during production, as it provides rapid results to compare product performance. Products developed for large scale commercial production are also documented in reverberation room tests according to EN ISO 354. These tests are performed by accredited third-party laboratories, and reports are available upon request.



Fire retardancy

All FiberAcoustic® products are tested and documented according to EN ISO 13501-1. All tests documenting the response to fire are performed by an external accredited test laboratory and full reports are available upon request in order to support architects, safety consultants and contractors.

The new standard EN ISO 13501-1 is considering three different aspects of response to fire: Fire resistance (B), Smoke development (s) and Burning drops (d). All FiberAcoustic® products are classified B-s1, d0 according to EN ISO 13501-1.

Sound absorption coefficient – $[\alpha]$

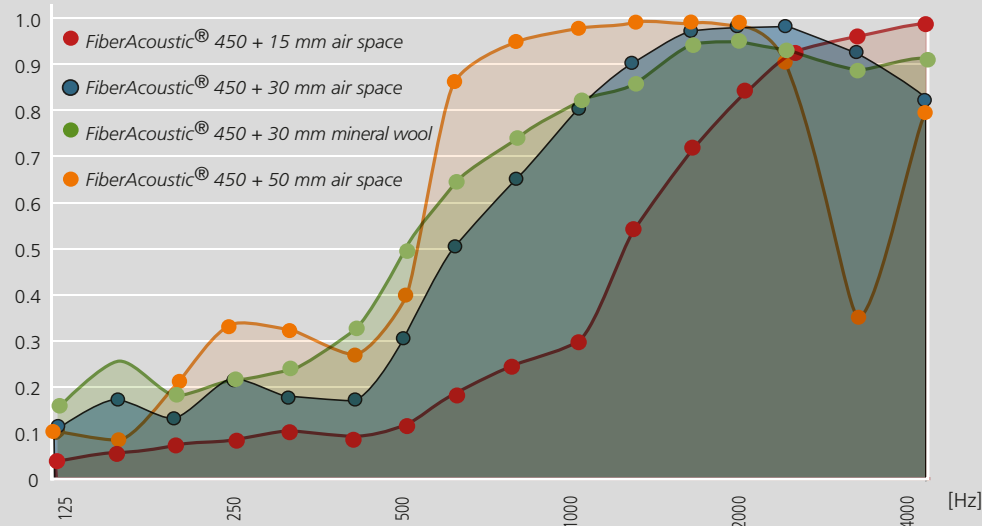

B

– in relation to flame behaviour

s1

– in relation to smoke development

d0

– in relation to flaming droplets/particles



FiberAcoustic® 75

Technical data

FiberAcoustic®	Standard	Unit	Value MD/CD
Weight	EN ISO 9864	g/m ²	75
Breaking strength	EN 29073-3	N/5 cm	25/35
Elongation at break	EN 29073-3	%	15/30
Thickness	EN ISO 9073-1	mm	0.3
Acoustic impedance		Ns/m ³	250
Fibre blend	100% FR polyester		
Treatment	Adhesive glue on one side (melt temp. 85°C)		
Length / width	Standard 100 metres / 600 and 1200 mm		
Colour	White and black		
Flame retardancy	EN ISO 13501-1: B-s1, d0		

MD: Machine direction CD: Cross direction

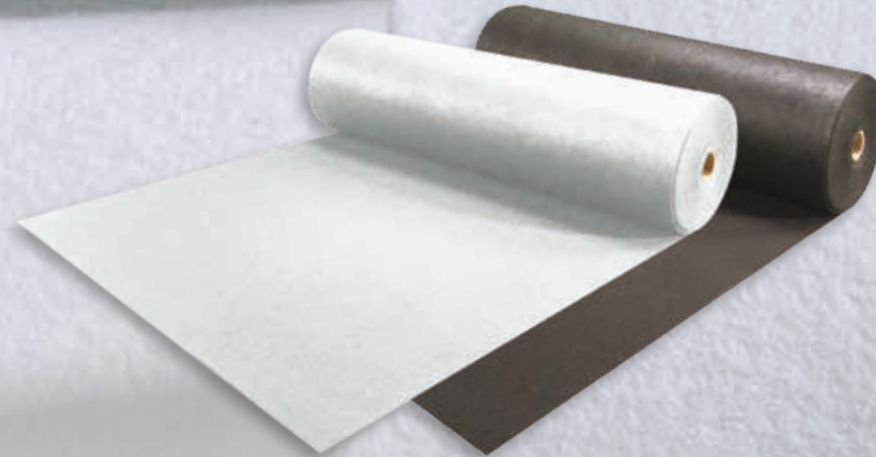

Sound absorption coefficient

Frequency [Hz]	100	125	160	200	250	315	400	500	630	800	1000	1250	1600	2000	2500	3150	4000	5000
Sound absorption [α]	0.05	0.04	0.10	0.19	0.28	0.41	0.54	0.58	0.57	0.50	0.41	0.55	0.61	0.59	0.62	0.63	0.63	0.58

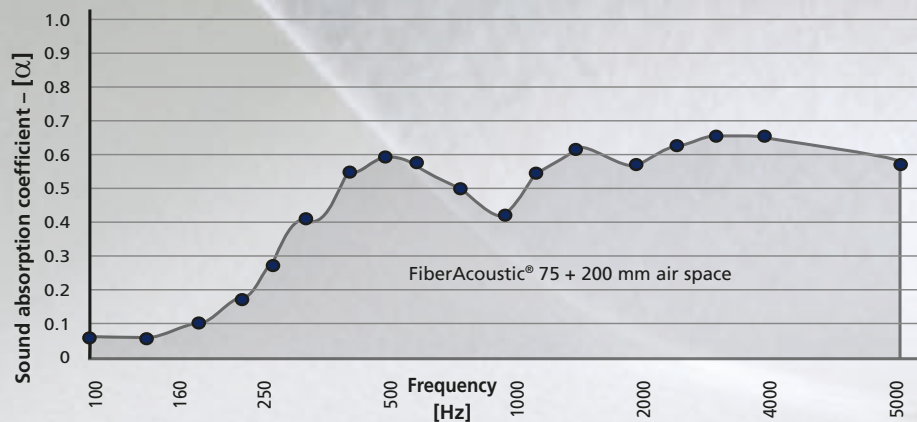

Material absorption coefficient in accordance with ISO 10535-2 and GB/T 18696.2-2002

Properties



FiberAcoustic® 450

Technical data

FiberAcoustic®	Standard	Unit	Value MD/CD
Weight	EN 29073-2	g/m ²	450
Breaking strength	EN 29073-3	N	425/800
Elongation at break	EN 29073-3	%	80/55
Thickness	EN 29073-1	mm	2.5
Acoustic impedance		Ns/m ³	600
Fibre blend	100% FR polyester		
Length / width	Standard 40 metres / 1150 mm		
Colour	White, black and coloured		
Flame retardancy	EN ISO 13501-1: B-s1, d0		

MD: Machine direction CD: Cross direction

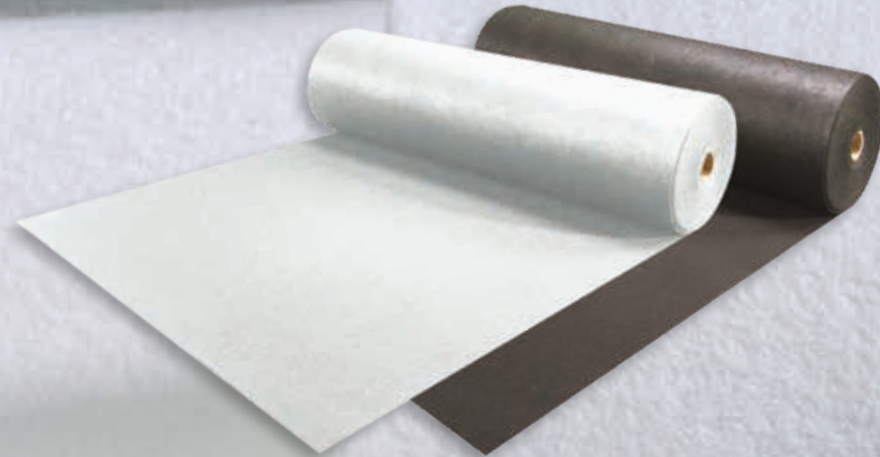

Sound absorption coefficient

Frequency [Hz]	100	125	169	200	250	315	400	500	630	800	1000	1250	1600	2500	3150	4000
Sound absorption [α]	0.17	0.21	0.50	0.56	0.67	0.85	0.91	0.95	0.93	0.78	0.66	0.84	0.83	0.85	0.90	0.91

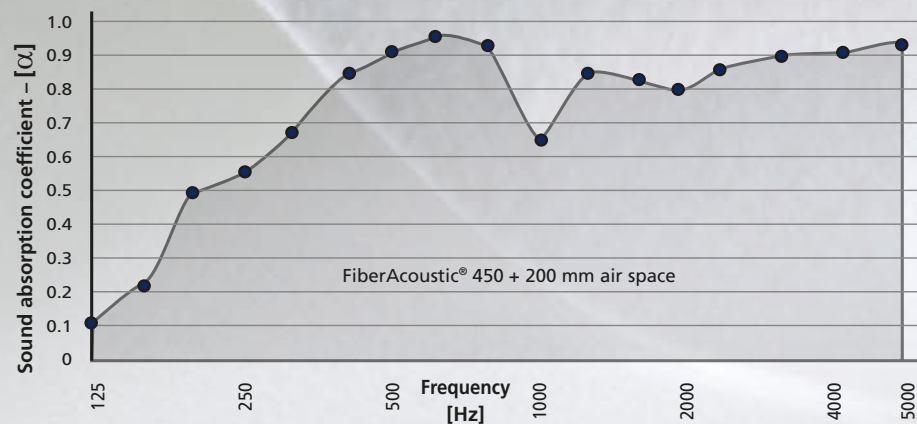

Material absorption coefficient in accordance with ISO 10535-2 and GB/T 18696.2-2002

Properties



FiberAcoustic® 450 Colours

FiberAcoustic® 450 can be supplied in any colour and offers the unique opportunity to be creative towards customer-specific designs, without compromising the acoustic performance.

- **Any colour which can be specified by NCS or Pantone® codes**
- **The ink does not affect the product's fire properties**
- **Customer-specific designs e.g. logos, pictures, slogans or patterns**
- **Unique creative solution options**
- **We encourage you to challenge us to provide state-of-the-art quality, performance and visual appearance**

NCS or Pantone®

There are different colour classification systems. Whether the colours you need are specified by NCS or Pantone® colour codes, we can make it. The code ensures that a chosen colour can be reproduced. This is especially important where a printed object or text is used to create an association with a specific company or product.



FiberAcoustic® – integrated in the applications

Allow the Fibertex design team to work with you, to design the most efficient sound absorption system for your specific application.

FiberAcoustic® products can be used in suspended ceilings or in acoustic wall panels. FiberAcoustic® also has superior acoustic performance for screens, offering a choice of face fabrics in any design or colour.

FiberAcoustic® products can also be used by the automotive industry for creating absolute comfort, by original equipment manufacturers in product fabrications, and even in the construction sector for reducing noise transported through the building.

Only our imaginations limit where FiberAcoustic® products can be used to improve acoustic performance.

Wall panels

FiberAcoustic® 450 has excellent sound absorption properties and is ideal for the construction of high-performance acoustic wall panels and ceilings. These products are extremely tough and punch resistant and are able to withstand most impacts without being damaged or losing sound absorption performance.

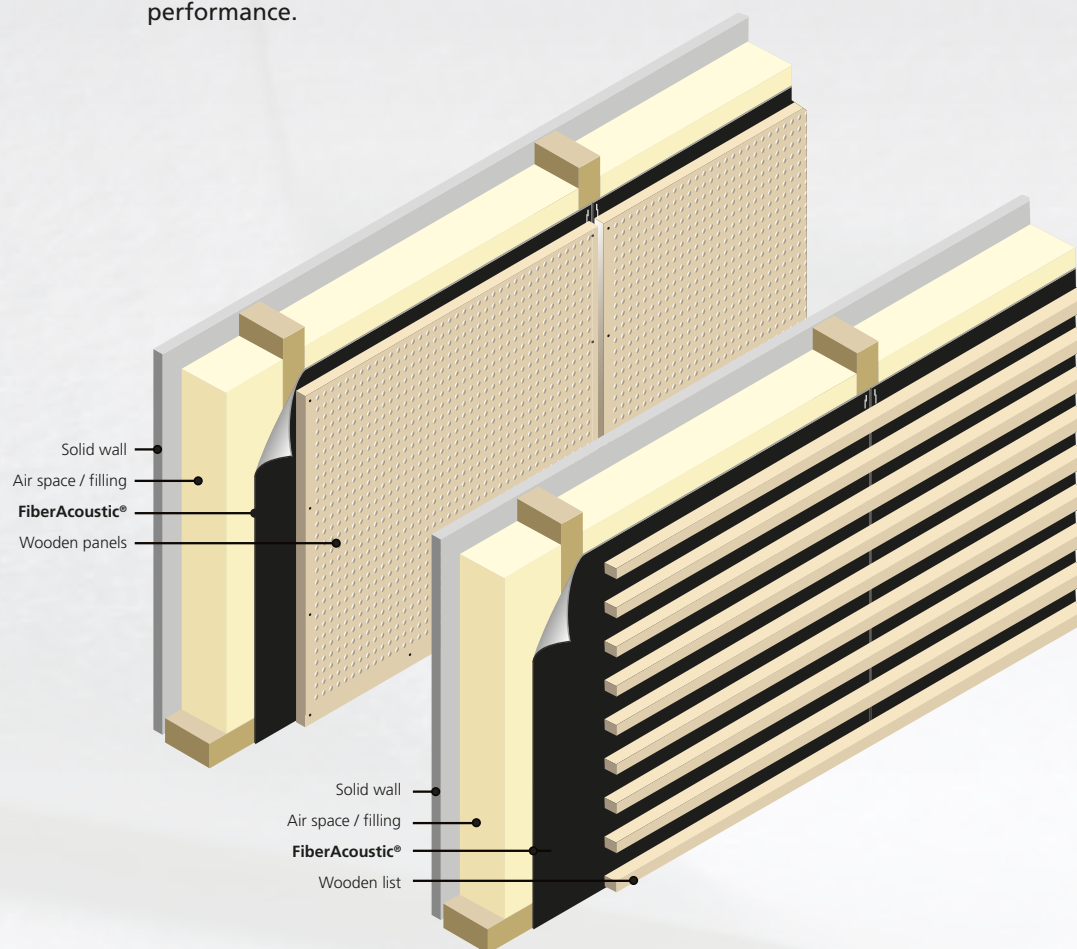

Suspended ceilings

FiberAcoustic® 75 is the ideal solution for integration in suspended ceiling systems for sound absorption. This material has an adhesive on one side for lamination. Although FiberAcoustic® 75 is strong, it is easy to cut to the right size and shape, making it effortless to work with at a construction site or in a heat press facility.

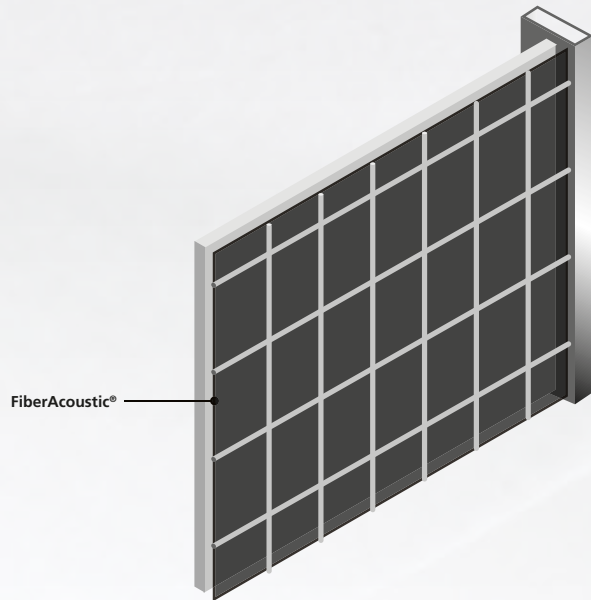
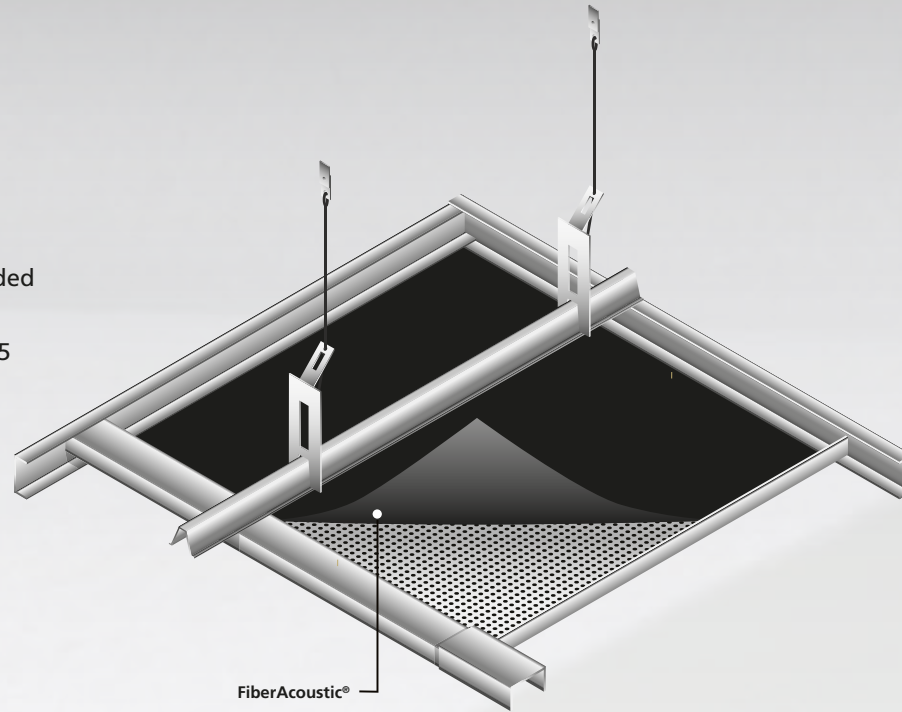

Highway screens

FiberAcoustic® products, which are tough and flexible, are also suitable for sound absorption in highway screens.

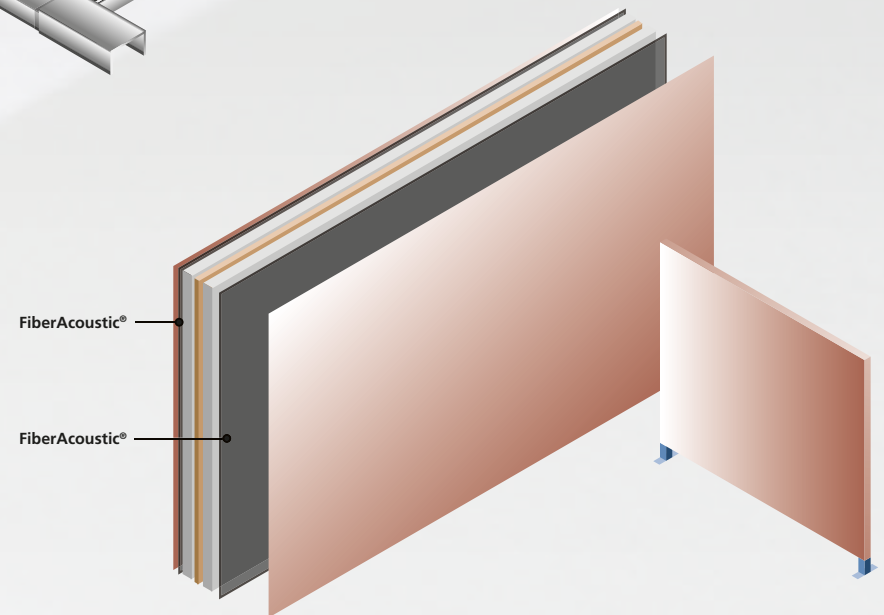

Screens

FiberAcoustic® provides superior noise absorbance in screens.

FiberAcoustic® – other applications



Flooring

Fibertex manufactures needlepunch nonwoven materials that dampen footstep noise in hard-floor applications.

These durable, user-friendly products are used with or without a moisture barrier foil and overlapping seams.

Fibertex products also compensate for minor unevenness in the subfloor construction.

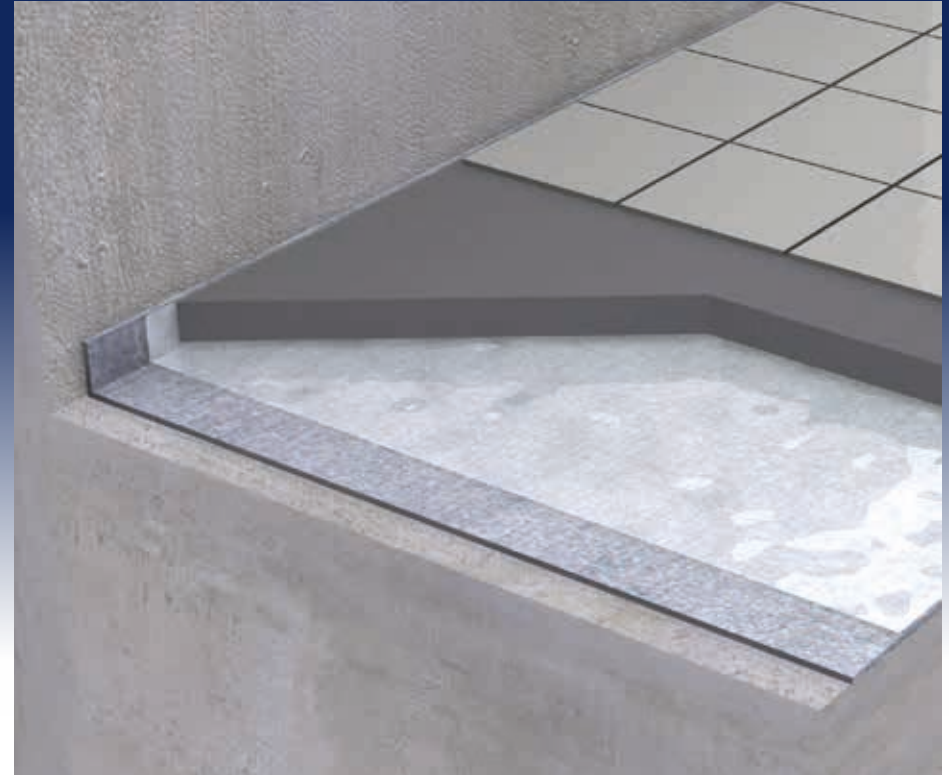

Construction

In construction where concrete slabs are used to separate individual stories of a building, one layer of Fibertex nonwovens is used in between the slab and the cast concrete flooring to reduce noise transported through the building.

The variety of FiberAcoustic® products offers unique opportunities for creative and performance-focused architects and constructors within a wide range of business areas. FiberAcoustic® will give you the solutions you need to meet your clients' requirements.



Whatever your sound absorption requirements – challenge us!



Furniture

The Fibertex team offers professional advice on how to incorporate acoustic materials into furniture for efficient sound absorption.

Applications include office screen walls, sound absorbing surfaces on the back of bookcases and surfaces underneath desks and sofas.

Allow us to work with you and to add value to your business.

Porous absorbers

Fibertex materials are used to reduce weight and minimise environmental impact in household appliances or industrial applications where the weight-performance ratio is critical.

Fibertex high loft nonwoven materials - based on virgin fibre or re-used materials - can replace traditional foam absorbers. For user convenience, Fibertex high loft fibre absorbers can be equipped with self-adhesive glue, ensuring easy installation.

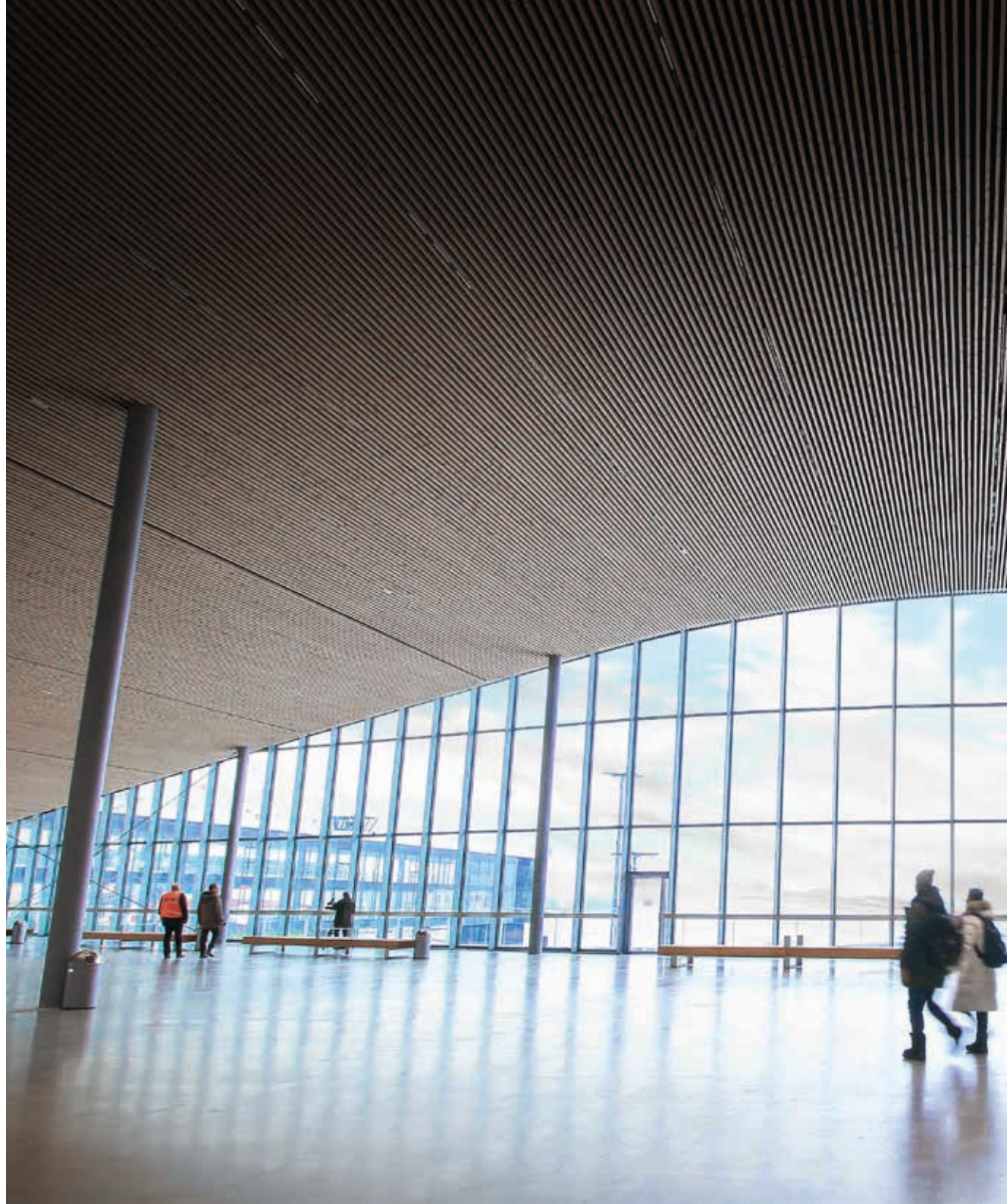
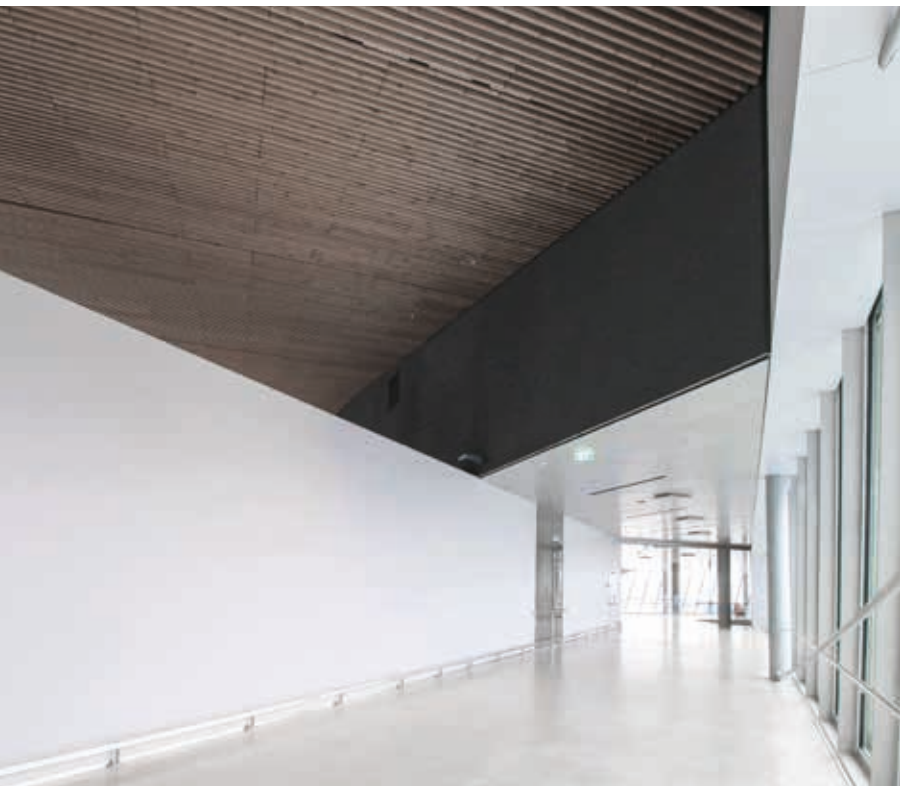



C A S E

FiberAcoustic® 450 in West Terminal 2 Helsinki, Finland

FiberAcoustic® 450 in black colour has been used behind solid wooden lists as an acoustic fabric in the passenger area of West Terminal 2.

Using FiberAcoustic® 450 offers the following benefits:

- **Excellent acoustic properties**
- **Noise reduction – unique sound absorption properties significantly improve the environment**
- **State-of-the-art quality, performance and visual appearance**
- **Fire resistance – classified B-s1, d0**

The product is extremely hard-wearing and shock-resistant and will withstand most impacts without being damaged and losing performance.

FiberAcoustic® nonwovens are textile-like and produced using fibres that provide significant benefits compared to competing technologies.

Installation and maintenance of wall panels

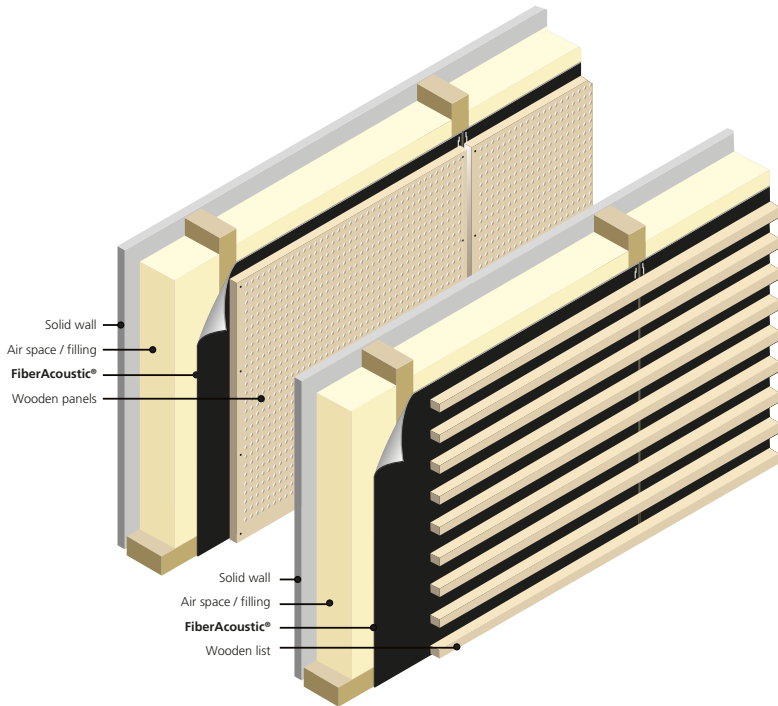

For use in wall panels FiberAcoustic® offers great installation flexibility. By nature, FiberAcoustic® is flexible and can be fitted and mounted in many ways and on all constructions.



FiberAcoustic® is resistant to all common cleaning detergents, and can be vacuum cleaned and/or wiped using a damp cloth.

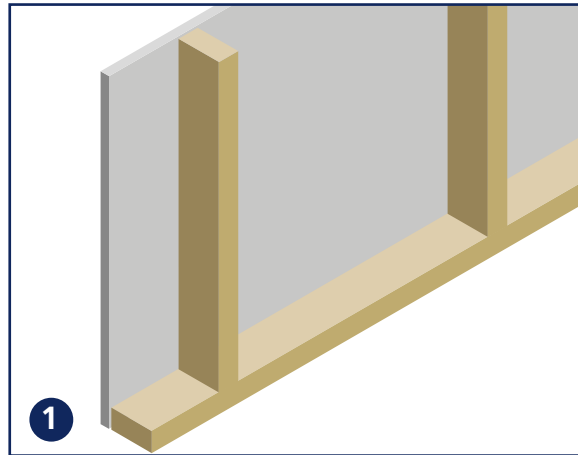

1 Built-up of wooden or steel structure.

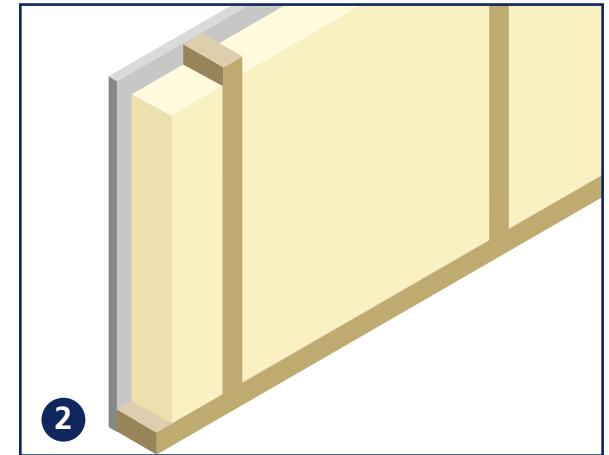

2 Mineral wool to be installed. It is important that the mineral wool is minimum as thick as the wood/steel laths.

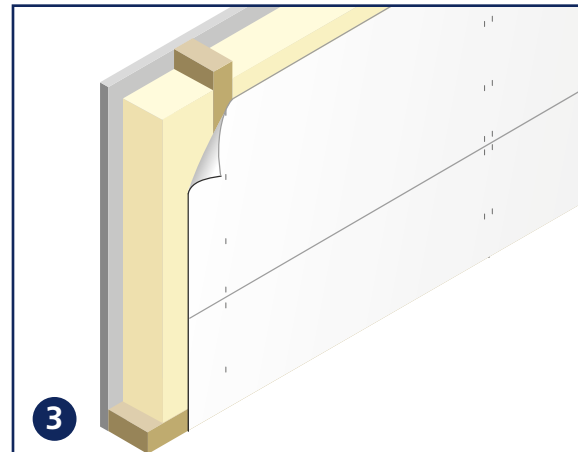

3 FiberAcoustic® is fastened by clamps, nails, screws or glue.

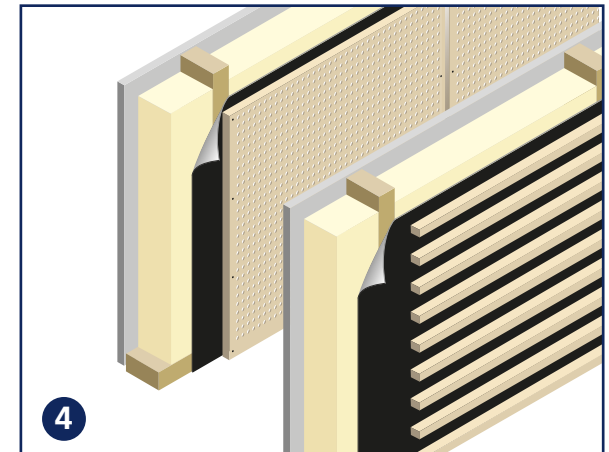

4 Panels or lists are installed.

Business areas



ACOUSTICS



AUTOMOTIVE



BEDDING

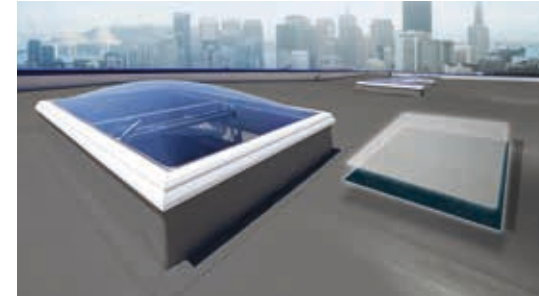

BUILDING INDUSTRY



COMPOSITES



CONCRETE



FILTRATION



FLOORING



FURNITURE



CIVIL ENGINEERING



MEDICO



WIPES

Benefit from our decades of **experience**



Fibertex is the leading global partner in technical and innovative performance-based materials and nonwovens solutions. We offer more than high-performance materials to our customers in more than 70 countries.

For over 50 years, we have improved nonwovens solutions for a variety of applications and business areas.

FIBERTEX.COM